

You are more than just a surgeon:

Social Media for Surgical Education

Brian Jacob, MD FACS

Disclosures

- Consultant / Teaching/Research Grant: Medtronic
- Consultant: Ethicon , Verb
- MAB: VIA Surgical, Lifebond
- RMD: angelMD
- Founder: IHC, inc



Innovations

- Come in infinite forms...



...But all start with an idea



US008192355B2

(12) **United States Patent**
Jacob

(10) **Patent No.:** US 8,192,355 B2
(45) **Date of Patent:** Jun. 5, 2012

(54) **ENDOLUMINAL COLOSTOMY SYSTEM AND PROCEDURE**

(75) Inventor: **Brian P. Jacob**, New York, NY (US)

(73) Assignee: **Mount Sinai School of Medicine**, New York, NY (US)

(*) Notice: Subject to any disclaimer, the term of this patent is extended or adjusted under 35 U.S.C. 154(b) by 859 days.

(21) Appl. No.: **10/798,246**

(22) Filed: **Mar. 10, 2004**

Prior Publication Data

US 2004/0225277 A1 Nov. 11, 2004

Related U.S. Application Data

(60) Provisional application No. 60/453,580, filed on Mar. 11, 2003.

(51) **Int. Cl.**
A61B 1/00 (2006.01)

(52) **U.S. Cl.** **600/184; 606/108**

(58) **Field of Classification Search** 600/184, 600/114, 128, 129, 135, 139, 201, 203, 204, 600/206, 585; 606/185, 170, 171, 108; D24/108, D24/112, 106; 604/164.01; 623/6.12

See application file for complete search history.

(56) **References Cited**

U.S. PATENT DOCUMENTS

5,071,408 A	*	12/1991	Ahmed	606/108
5,312,351 A	*	5/1994	Gerrone	604/117
5,360,414 A	*	11/1994	Yarger	604/264
5,380,290 A	*	1/1995	Makower et al.	604/164.01
5,400,768 A	*	3/1995	McNamara et al.	600/104
5,599,304 A	*	2/1997	Shaari	604/94.01
6,517,518 B2	*	2/2003	Nash et al.	604/164.02

* cited by examiner

Primary Examiner — Ryan Severson

(74) *Attorney, Agent, or Firm* — Fish & Richardson P.C.

(57)

ABSTRACT

A trocar for positioning within a body lumen such as an intestine is disclosed. The trocar has a window adjacent its distal end in communication with the internal lumen of the trocar. The trocar is sufficient rigid to stabilize the body lumen upon positioning therein to maintain patency of the body lumen. A slot in communication with the window extends to the distal end of the trocar.

A surgical procedure for reversing a colostomy procedure is also disclosed. The above described trocar is inserted into a first intestinal section through an opening in the abdominal wall. A guide wire is introduced through the rectal opening and advanced through the rectal stump and out the opening in the abdominal wall. An anvil is connected to the guide wire and the guide wire withdrawn through the rectal opening to advance the anvil within the first intestinal section. An anastomosis instrument is introduced through the rectal opening and connected to the anastomosis instrument. The anastomosis instrument is fired to connect the two intestinal sections to reestablish continuity between them.

19 Claims, 10 Drawing Sheets

Patents

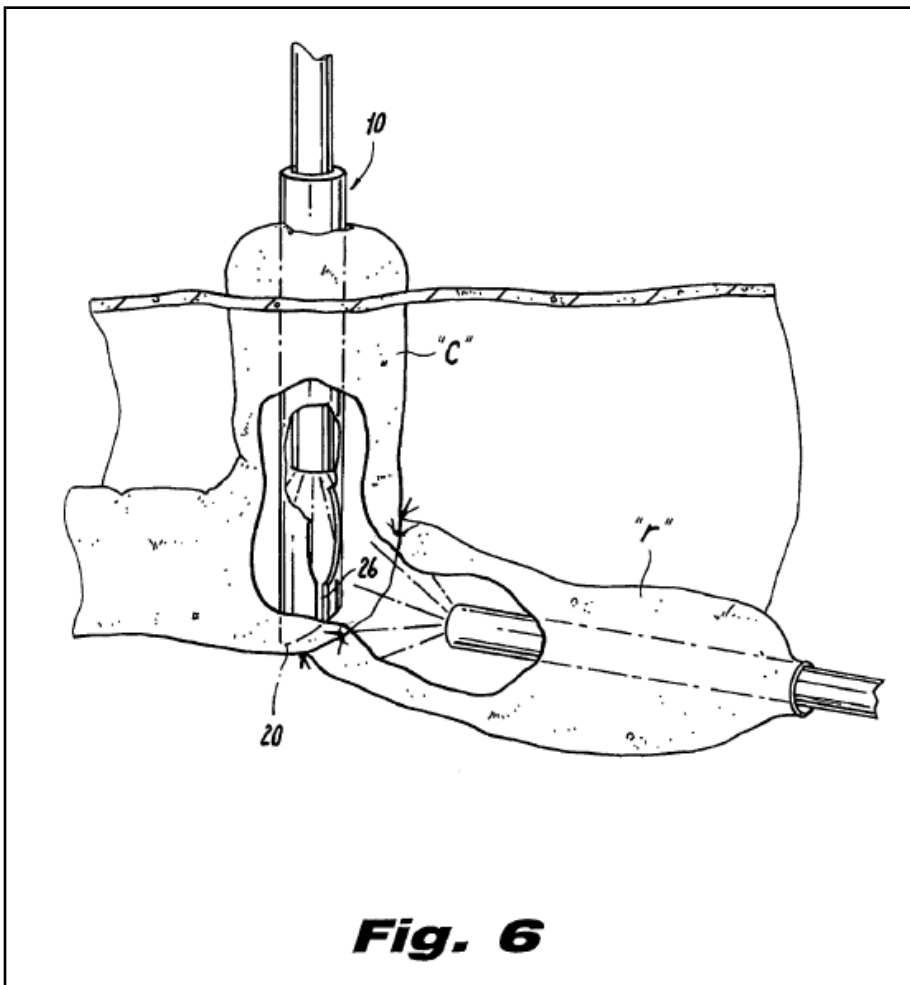
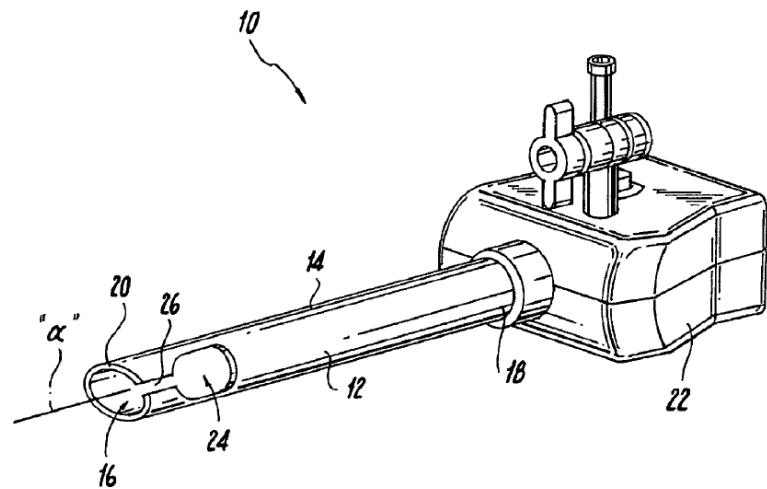

Fig. 6



(12) **United States Patent**
Jacob

(10) **Patent No.:** US 8,192,355 B2
(45) **Date of Patent:** Jun. 5, 2012

Start-ups



Founders: Brian Jacob, MD and Mor Zweil.

angelMD Acquires IncLinx - Investment Matchmaking Software Startup

Apr 17, 2014

San Francisco, CA (PRWEB) April 17, 2014 -- [angelMD](#), the investment marketplace that connects physician investors and leading medical startups, today announced that it has acquired [IncLinx](#), a software company developing technology to create matches between investors and investment opportunities.

IncLinx, based in New York City and Tel Aviv was created by Brian P Jacob, MD an internationally recognized hernia surgeon and entrepreneur, and Mr. Mor Swiel (LL.B. LL.M.) a corporate and commercial attorney with extensive involvement in the Israeli startup marketplace. Dr. Jacob and Mr. Swiel, with the assistance of Agiletree, a software development company, created technology to foster matches between potential investors and companies seeking investment based on a rich and evolving set of criteria. 

Dr. Jacob will join angelMD as Regional Medical Director - NY while Mr. Swiel will serve as a Senior Advisor for the team in the Israeli market.



Passion

- Not every innovative idea will “change the world”, but as much **passion** should be felt about the idea, the team, and the marketplace, as if it could.

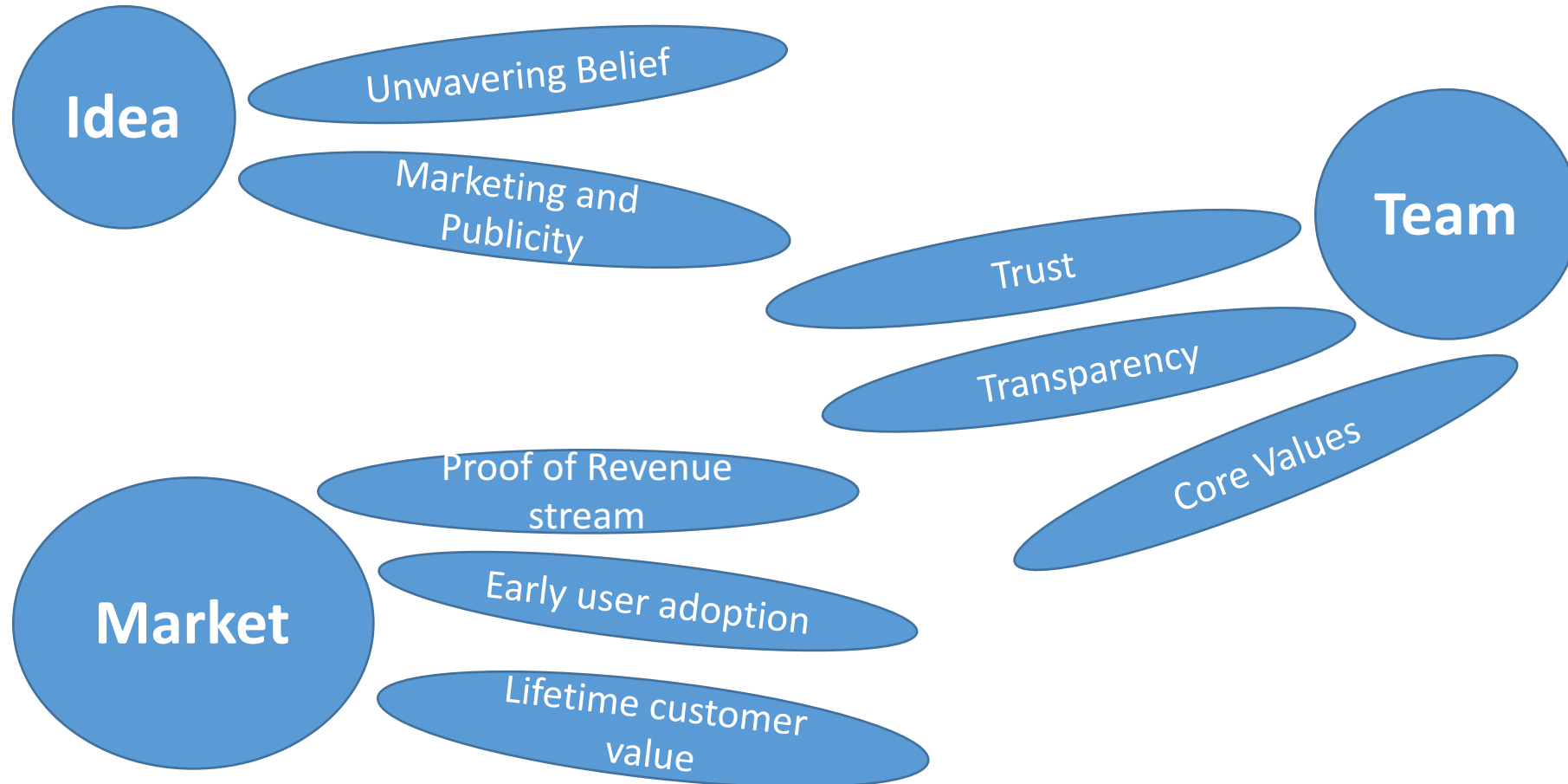



Michael Paul Meara was live.

4 hrs

John Porterfield and Trainees in a Robotic Practice.

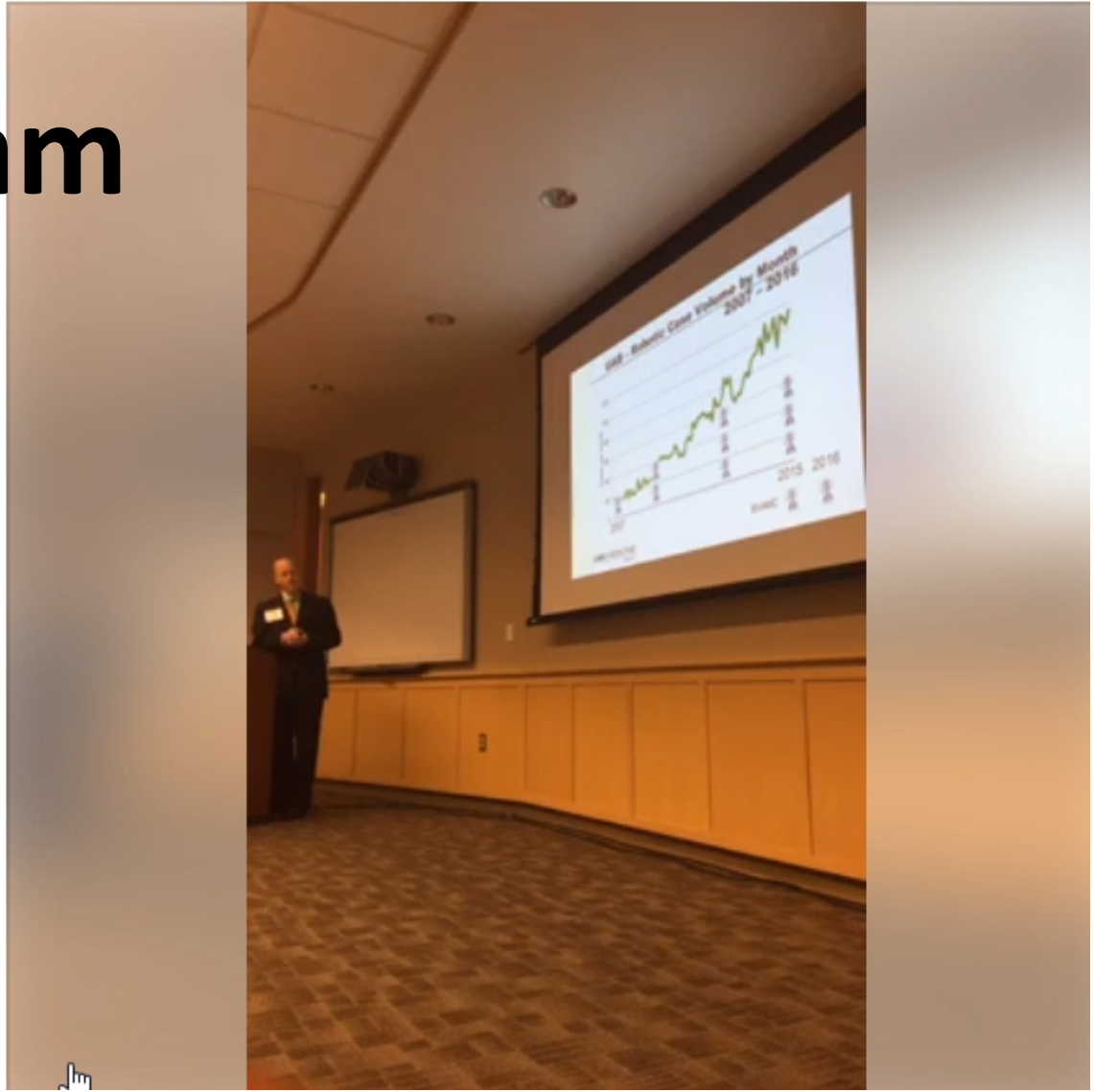

11/4/16 at 10am

Ohio State University

11/4/16 at 10am

Mexico

Live surgery

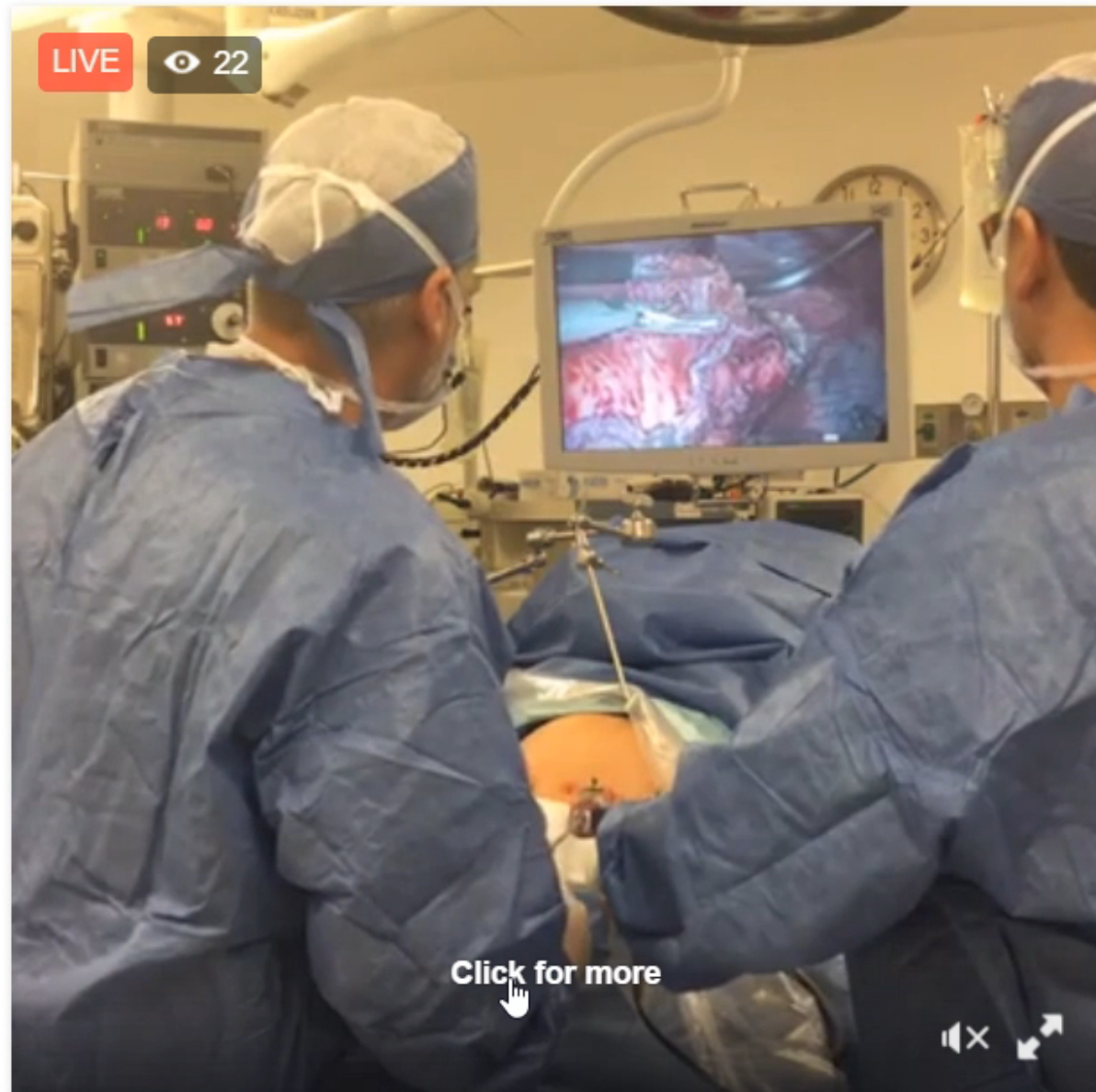



Lucian Panait

23 hrs · Pleasantville, NJ

71 year-old female S/P Hartmann procedure for perforated diverticulitis 9 months ago. Now ready for colostomy reversal, but also has large incisional hernia. I feel that she would be best served by a TAR. I am curious who would do this in one setting versus staging the hernia repair at a later time after the colostomy reversal.



Operative planning

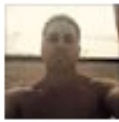

Mario Leyba

October 30 at 11:53pm

I had never seen a SPIGELIAN hernia in my practice then saw two in one week. Fixed both with rTAPP approach and progrid. Constructive criticism apologize upfront for the music. I was listening to some Bob [unclear] background and Facebook frowns against posting with music 🎵 so I used the one on iMovie to replace it for posting.

Learning Procedures

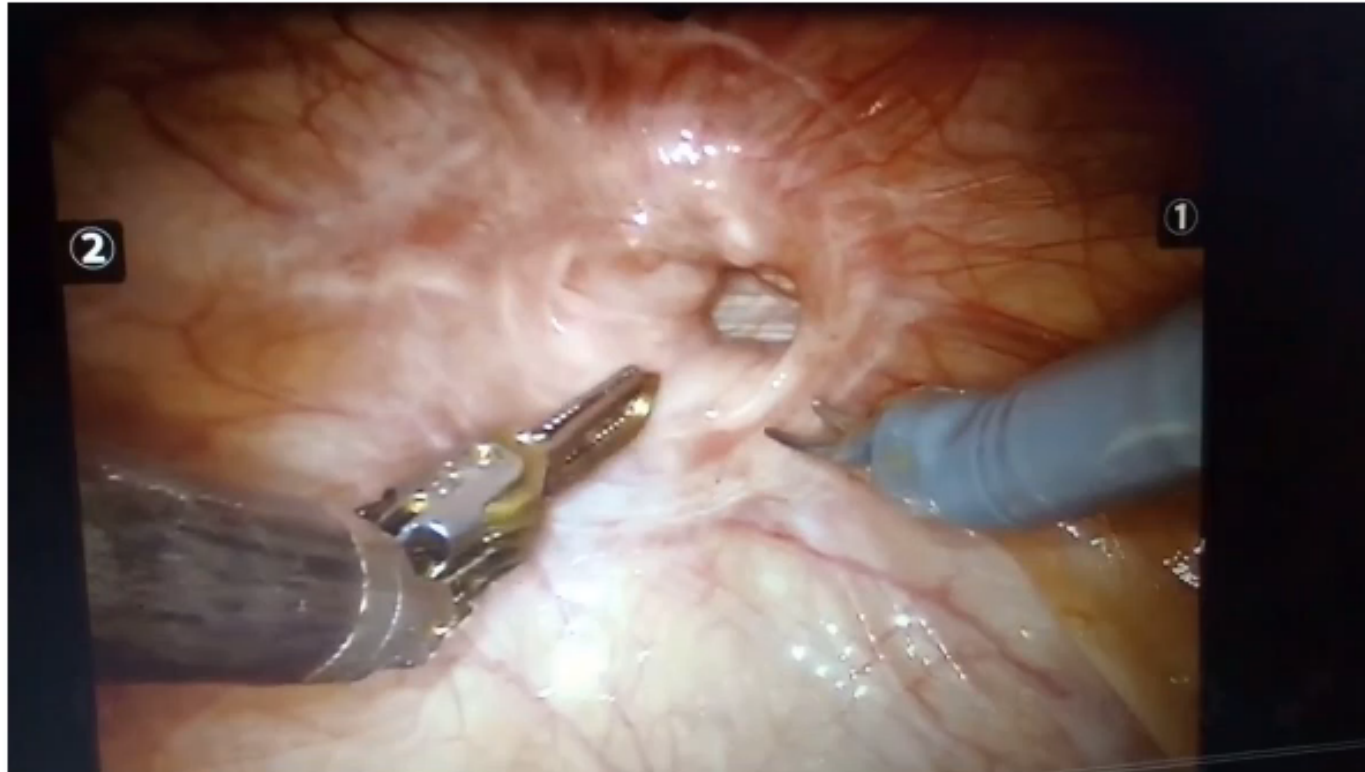

Medicine and Surgery today





Surgeon experience grows over time, so our opinions evolve

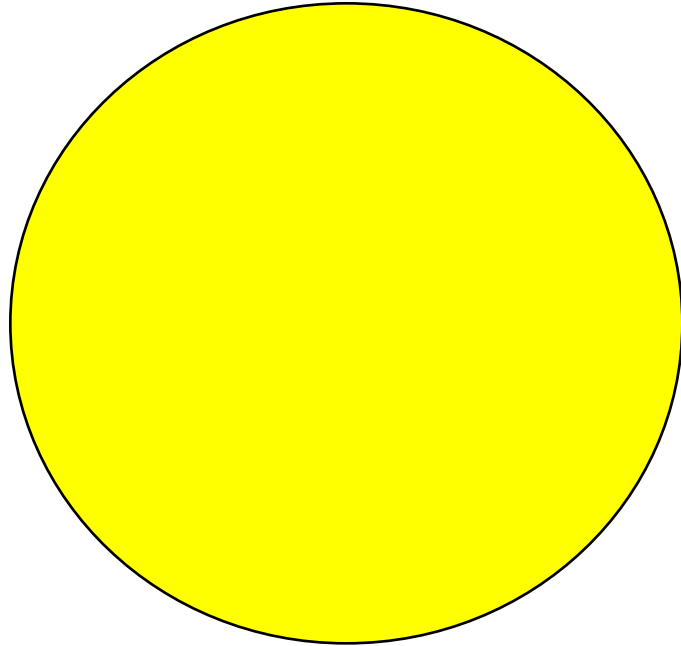

Dr. Melvin

Size of the yellow dot = experience

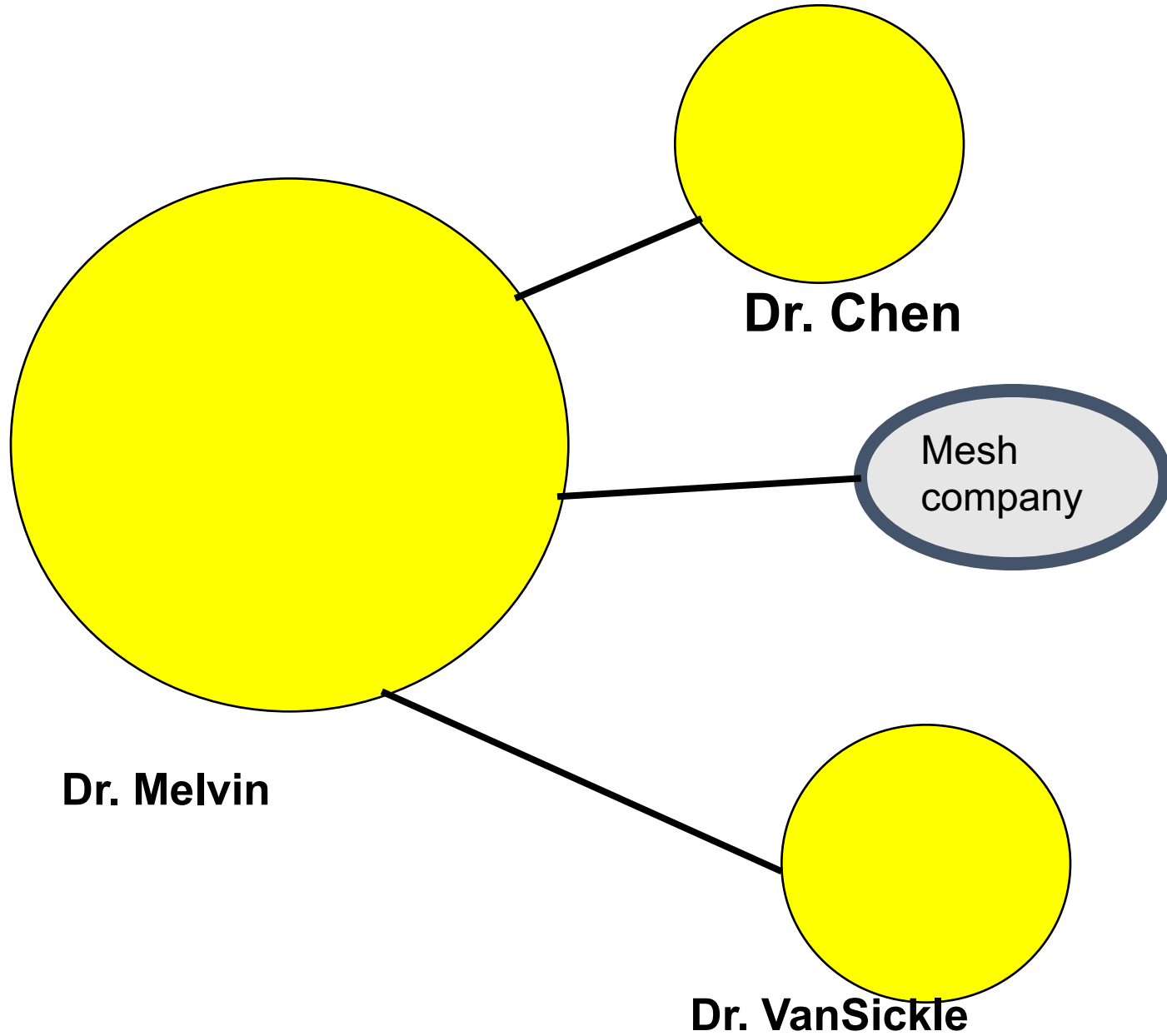

Surgeon experience grows over time, so our opinions evolve

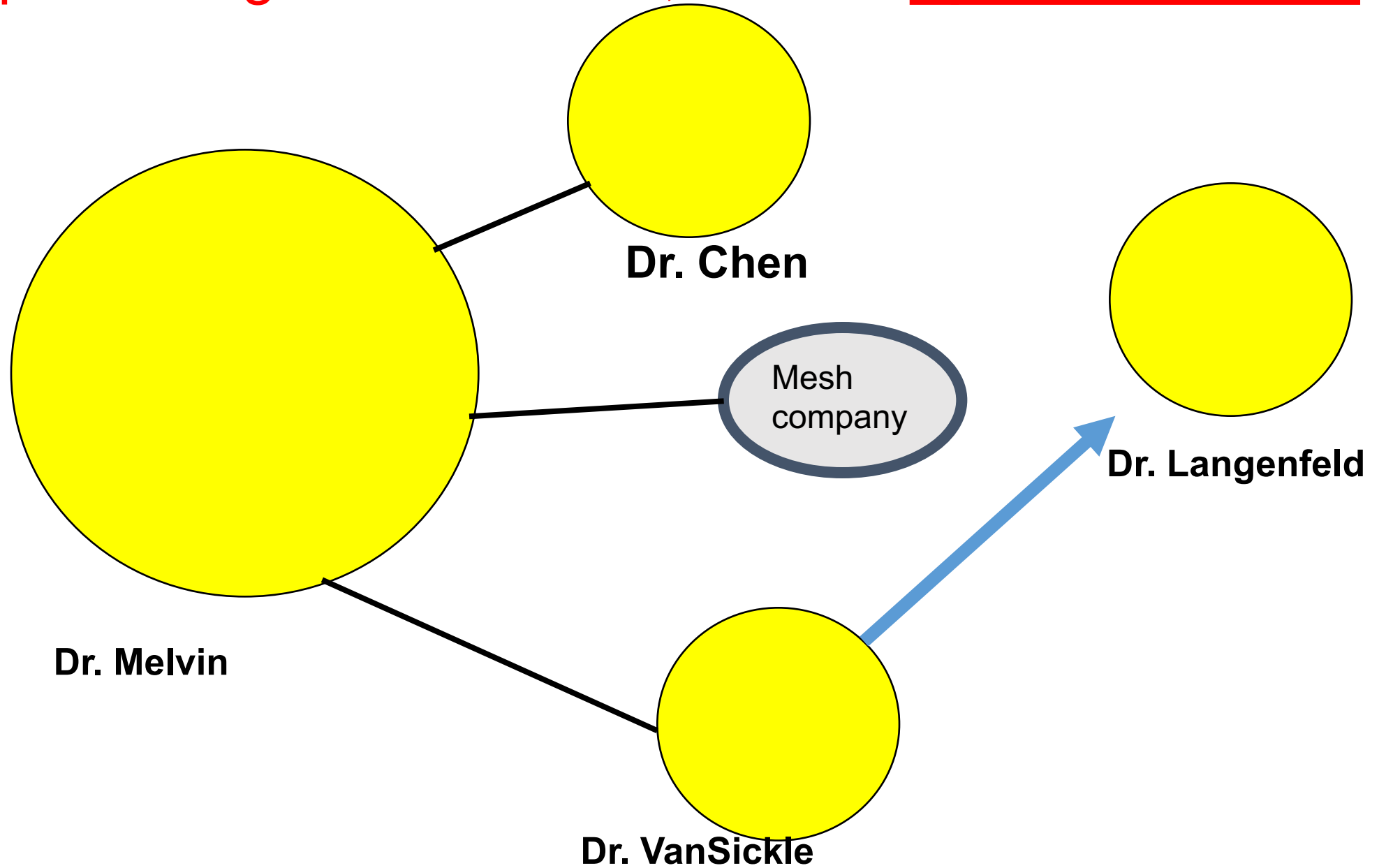

The global physician / industry network

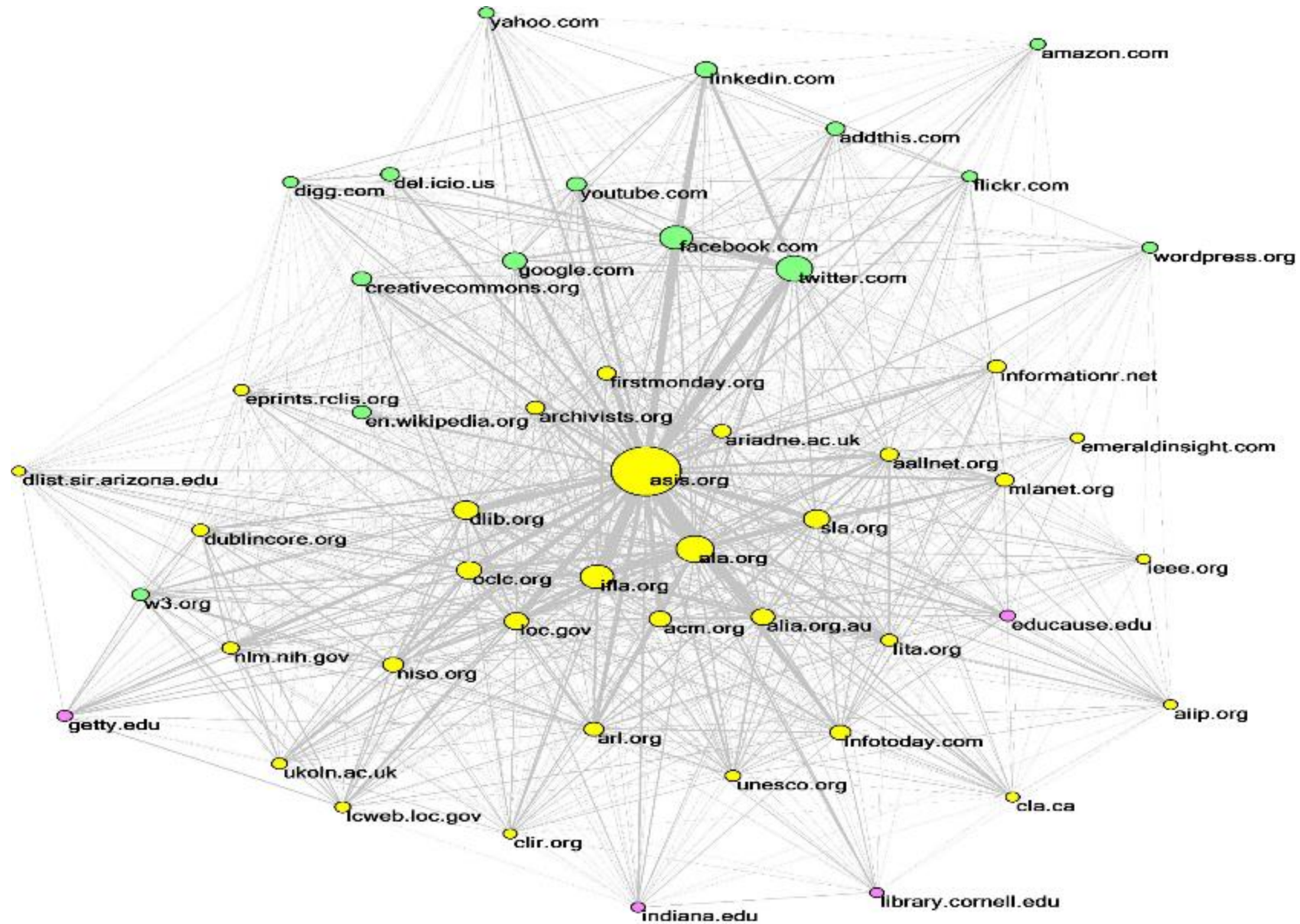

Orbera™ Intragastric Balloon



Brian Jacob

I have lady from brazil in an ER in NYC who had an Obera intragastric balloon. She was told if she urinated blue, to go to an ER. She urinated blue. What does this mean? Anyone have experience with this balloon?

Like · Comment · January 25 at 9:18am via BlackBerry Smartphones App

Brian Jacob

I have lady from brazil in an ER in NYC who had an Obeira intragastric balloon. She was told if she urinated blue, to go to an ER. She urinated blue. What does this mean? Anyone have experience with this balloon?

Like · Comment · January 25 at 9:18am via BlackBerry Smartphones App

 Tomasz Bogala and 7 others like this.

 View 25 more comments

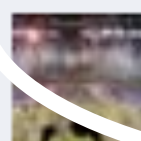

Brian Jacob What an amazing use of social media for #quality #improvement. Between IBC and other communities (IHC), we are all collaborating globally in real time, and consequently we are optimizing the care our patients receive (egos hung up at the entry door). T...

[See More](#)

January 26 at 7:54pm · Like ·  6



Helmuth Billy Congratulations Brian for safely navigating this problem this is a good forum

January 26 at 8:22pm · Like ·  3



Luis Rodriguez Thank you to some behind the scenes great industry and surgeon collaboration. At the end of the day, it's about the patient, doctors and nurses. #proud #credo

January 26 at 8:42pm · Edited · Like



Tap into the Network

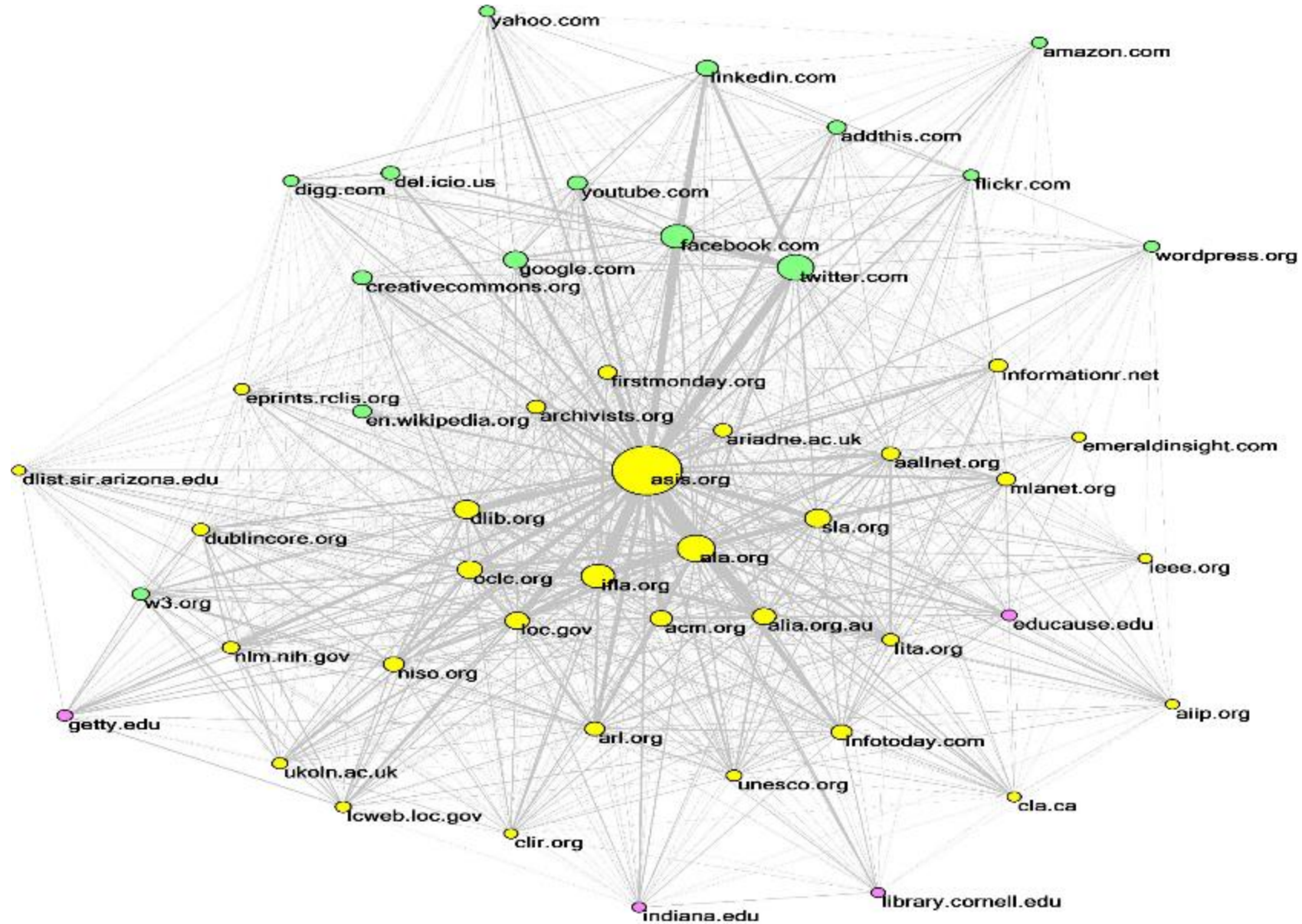

Current Collaboration Method: Meetings



Brian P Jacob

Current Collaboration Method: Research

Outcomes of Synthetic Mesh in Contaminated Ventral Hernia Repairs

Alfredo M Carbonell, DO, FACS, Cory N Criss, MD, William S Cobb, MD, FACS, Yuri W Novitsky, MD, Michael J Rosen, MD, FACS



Current Collaboration Method: Hands-on training



Educational meetings
Research
Training / mentorship

All current surgeon collaboration efforts: ripe for disruption



Brian P Jacob

1 Step 1: Placement of Staple Line
2 Step 2: Placement of Staple Line

26
Placement of Staple Line
18 sec

41
High lateral Staple Line
18 sec

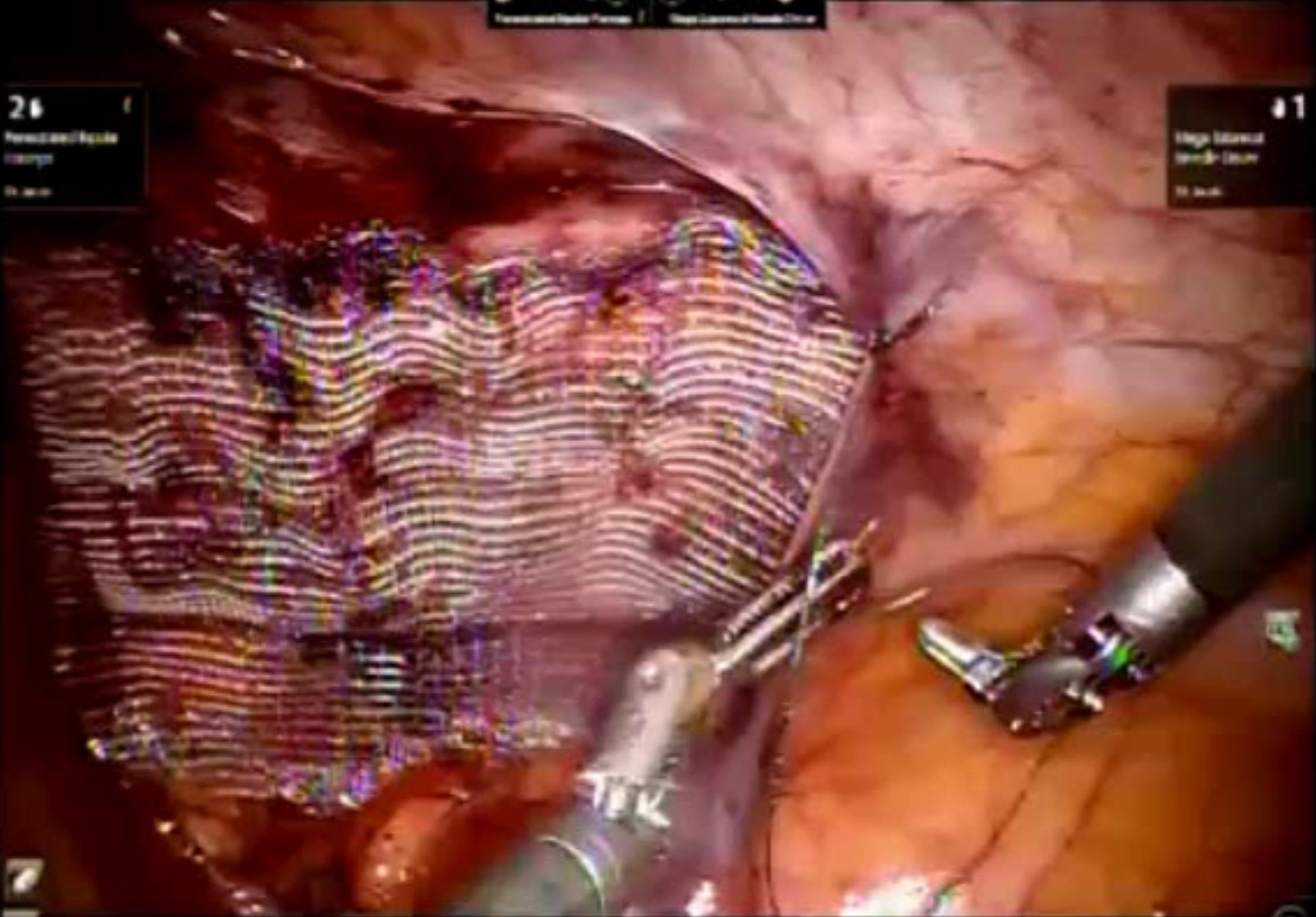



Medicine and Surgery Tomorrow



1.5 billion people on FB

Mark Zuckerberg

“When I created Facebook in 2004,
I did not want to create a company,
I wanted to solve a problem.”

Webpages vs. UGC platforms

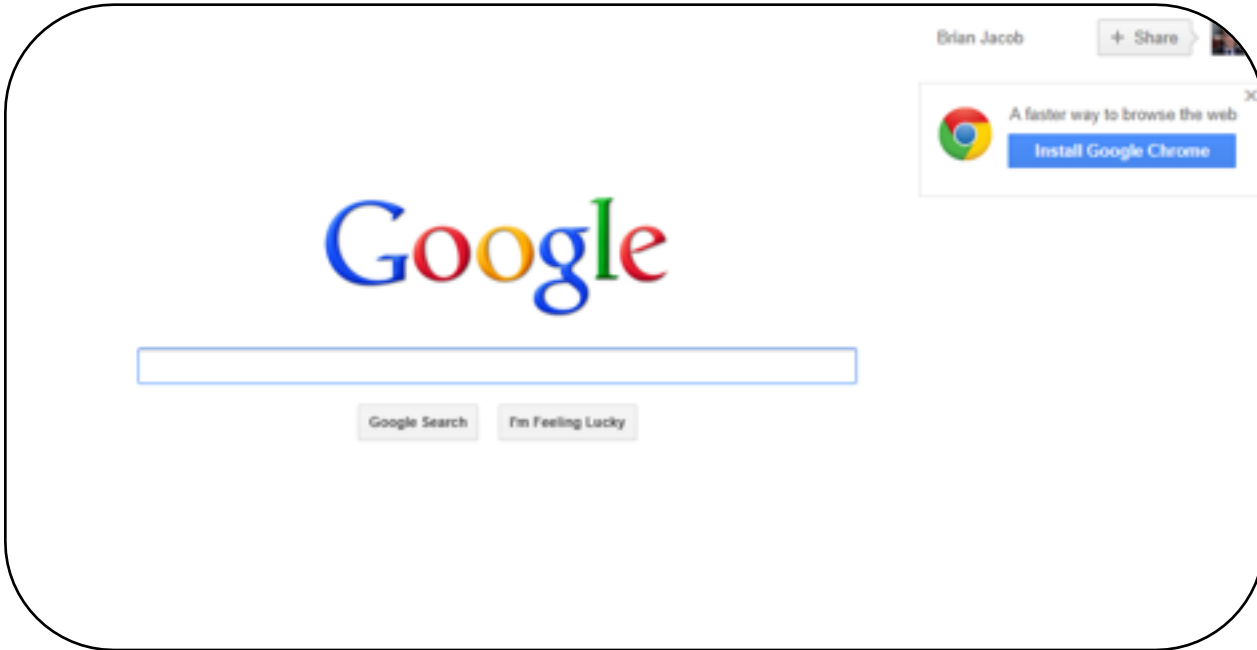

Ugc = user generated content websites (social media)



Michael Rosen

October 6 at 11:06pm · 

Go Tribe!!!!



 Like

 Comment

 Share

41% growth by users aged 35-54

USL	[AS OF JANUARY, 2011]		[AS OF JANUARY, 2014]		GROWTH
	USERS	PERCENTAGE	USERS	PERCENTAGE	
GENDER					
<i>Total US</i>	146,805,000	100.0%	180,000,000	100.0%	22.6%
AGE					
13-17	13,114,780	8.9%	9,800,000	5.4%	-25.3%
18-24	45,406,460	30.9%	42,000,000	23.3%	-7.5%
25-34	33,171,080	22.6%	44,000,000	24.4%	32.6%
35-54	39,595,900	27.0%	56,000,000	31.1%	41.4%
55+	15,516,780	10.6%	28,000,000	15.6%	80.4%



Increased growth of more professional-aged people

Social media sites, 2012-2014

% of online adults who use the following social media websites, by year

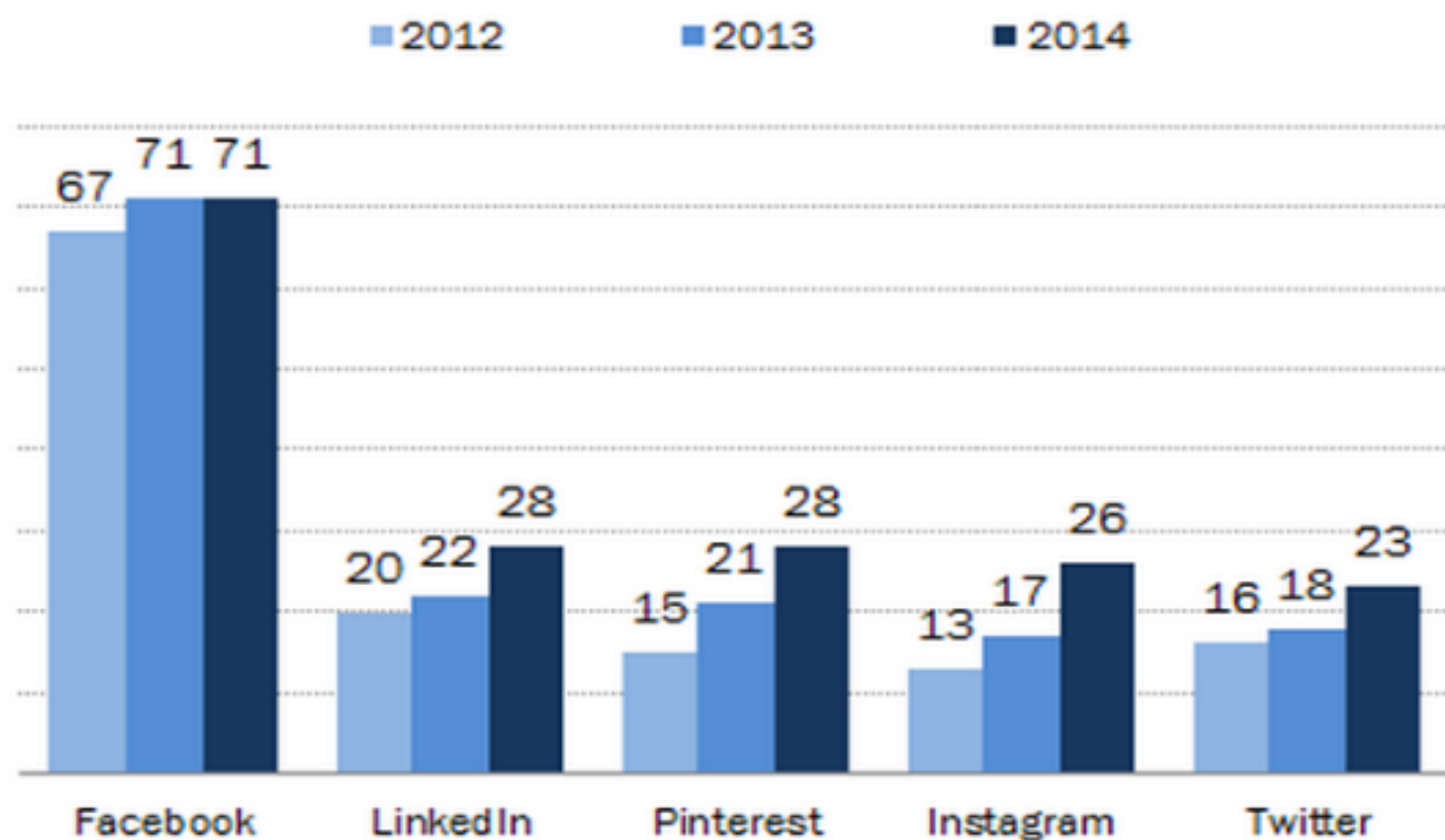

Pew Research Center's Internet Project Surveys, 2012-2014. 2014 data collected September 11-14 & September 18-21, 2014. N=1,597 internet users ages 18+.

PEW RESEARCH CENTER

Facebook evolution of Online Collaboration

2016

2004

Texting

- “Robot is better than Open surgery”

Photos

Video

Live

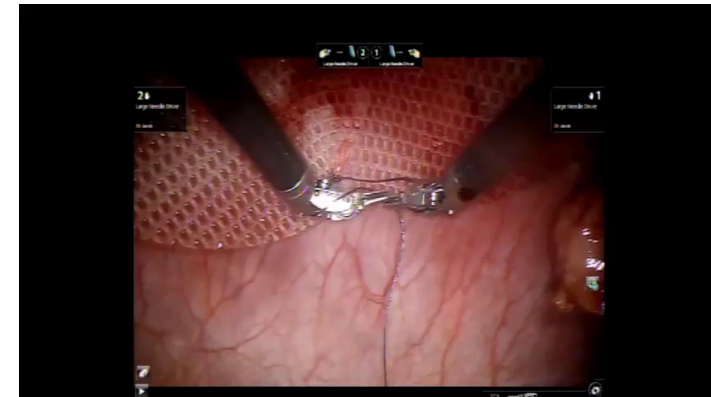

Brian P Jacob

Social Media Concerns

- **Social Media in Surgery MAY Attract**
 - Potentially addictive people
 - Self Promoting people
 - Projecting false self
 - Narcissistic behavior
 - Heavily conflicted

REVIEW ARTICLE

Journal of Behavioral Addictions 3(3), pp. 133–148 (2014)
DOI: 10.1556/JBA.3.2014.016
First published online August 26, 2014

The uses and abuses of Facebook: A review of Facebook addiction

TRACII RYAN^{1*}, ANDREA CHESTER², JOHN REECE¹ and SOPHIA XENOS¹

¹School of Health Sciences, RMIT University, Melbourne, Victoria, Australia

²School of Design and Social Context, RMIT University, Melbourne, Victoria, Australia

- **Narcissism**
 - Highly correlates with activity on social media
 - Present oneself in a more favorable way than reality

And this is a good idea for surgical education, Why?



likeable social media

How to DELIGHT YOUR CUSTOMERS,
Create an UNDISPUTABLE BRAND,
and So Much More by
AMAZING ON FACEBOOK
(and other social networks)

DAVE KERPEN

11 Principles of a likeable business

Listening

Storytelling

Authenticity

Transparency

Team Playing

Responsiveness

Adaptability

Passion

Surprise and
Delight

Simplicity

Gratefulness

Social Media is Adaptable

- “Social media is about creating organizations, ones that listen to customers and are responsive and transparent in their interactions.”
 - Dave Kerpen – Founder (and friend), Likeable Media (www.likeable.com)

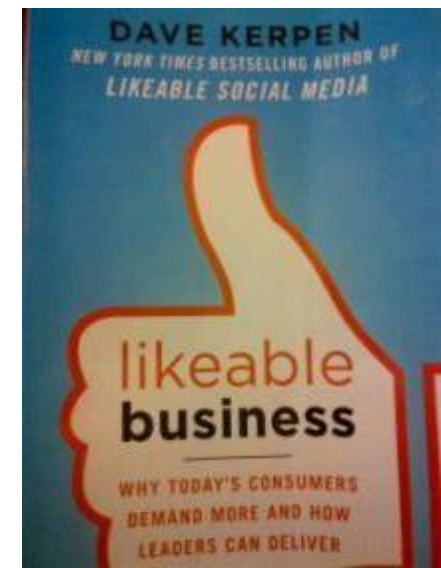

Facebook **Groups**



User generated content – Facebook GROUPS



Humble beginnings of the IHC: International Hernia Collaboration



Dec 17, 2012





9 initial members

relief. I inject ml of 0.5 percent bupivacaine and 1ml kenalog. Would at least tell that is pain trigger site if he gets temporary relief.
December 17, 2012 at 11:07pm · Like

 **Phillip Rosett** You mention pain with intercourse. Is it pain during, by pressure on a trigger point or pain during ejaculation?
December 18, 2012 at 11:00pm · Like

 **Brian Jacob** Friends, so the pain is quite near that angle (bend) (fold) in the mesh. 3 ultrasound guided injections near that spot each provide immediate, but less than 48 hour relief. The trigger is always direct pressure on the one spot (pressing , bumping w/intercourse, full bladder). The op report and discussion with the original surgeon suggest it was expertly done. The pain was not present before hand and MRI shows normal neuromuscular anatomy and no pubalgia. The only thing I can think of is that fold in the mesh, or maybe the gen branch of the gfn , but he has no scrotal pain or hypersensitivity. For now, he can tolerate this and thus we are holding off on operative intervention, but should the time come When pt can't tolerate the pain any more, I then plan to look laparoscopically. Agree?
December 23, 2012 at 10:21am · Like ·  1

 

29000

Vetted members

900 requests to join

How much content are we creating? IHC

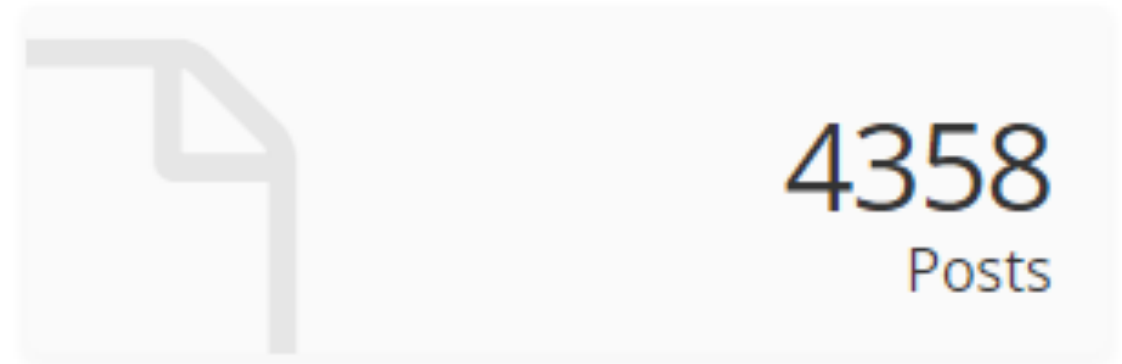
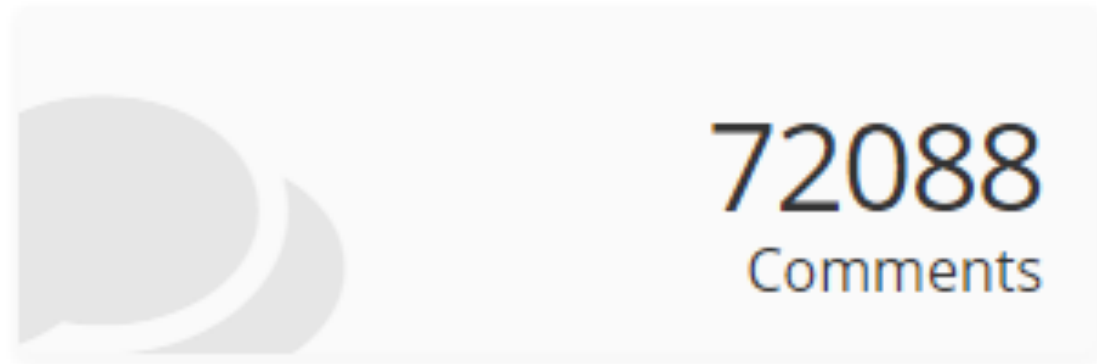

Engaged user spends **5.7** hours per week on IHC

Impact Factor (citations in 2016 / # articles in 2015)

New metric for fb groups: comments / posts (value score). Value score of 16.54

Shared learning by the IHC

- eTEP
- MPO
- ECS
- Onlay
- Rtapp
- Tar
- Rtar

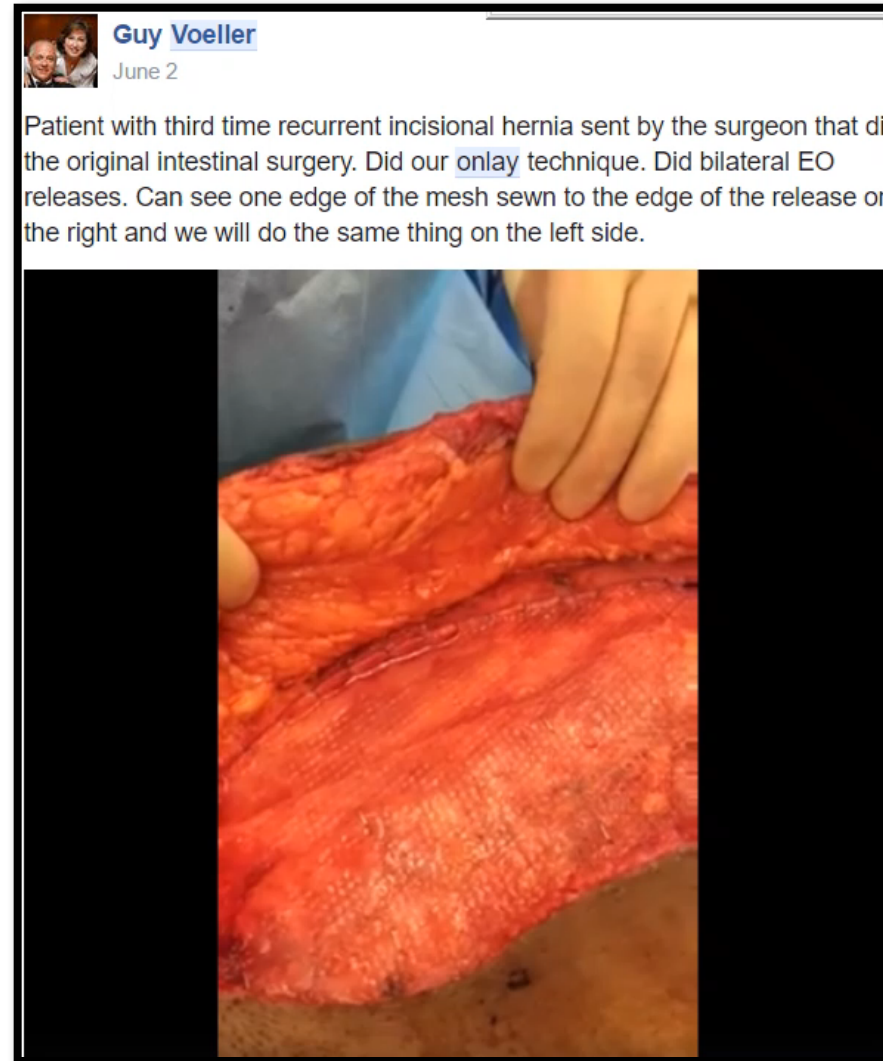

Truly global mentoring (rTAPP)



Filip Muysoms 😊 feeling happy at 📍 AZ Maria Middelaers.

September 2 at 9:42am · Gent, Belgium

first experience with [rTAPP](#). did 3 bilateral hernias between 8:00 am and 2:15 pm. proctored by Archana Ramaswamy very happy about the whole team. well done !



(Lap subcutaneous umbilical hernia, with onlay)



between legs. 3 ports in previous Pfanistiel incision. No IPOM mesh, no tackers. Cheap for my reality....

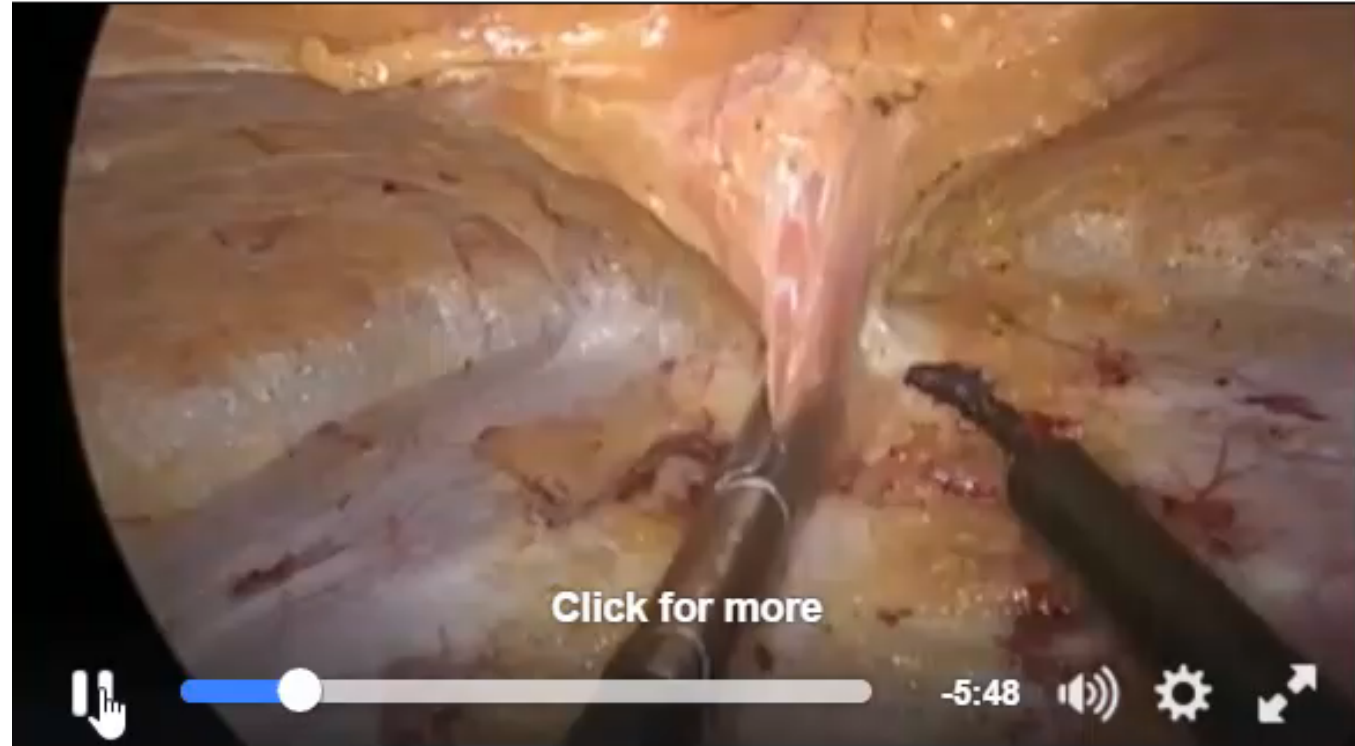

Global spreading New trends (ipom to retrorectus)



Rakesh Kumar Sinha

April 30 · Mumbai, India

Changing trends from IPOM to placement of mesh extra peritoneal by lap TEP or Lap TAR where we can prevent adhesions of mesh to the intraperitoneal structures , did open bilateral TAR with placement of 30*30cm mesh.

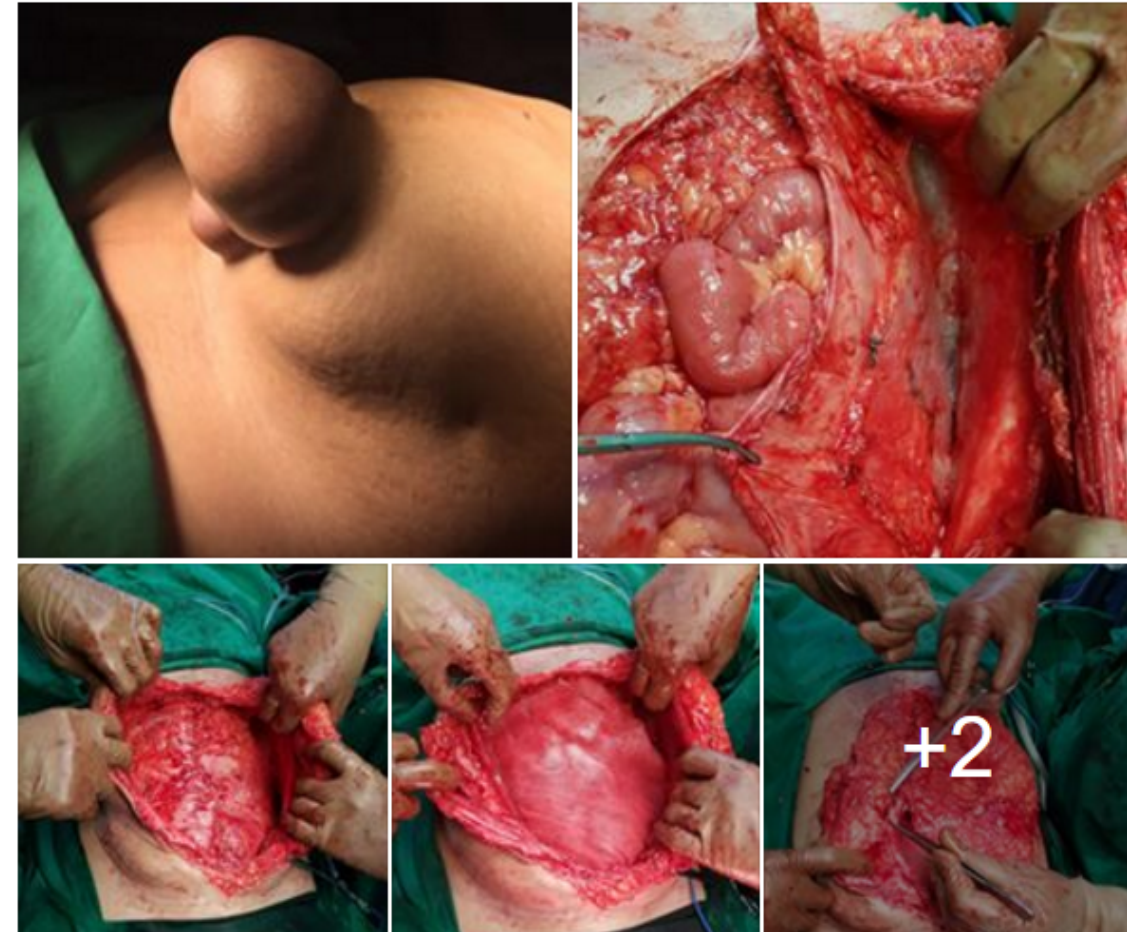

Conrad Ballecer, Hari Kumar Ondiveeran and 16 others





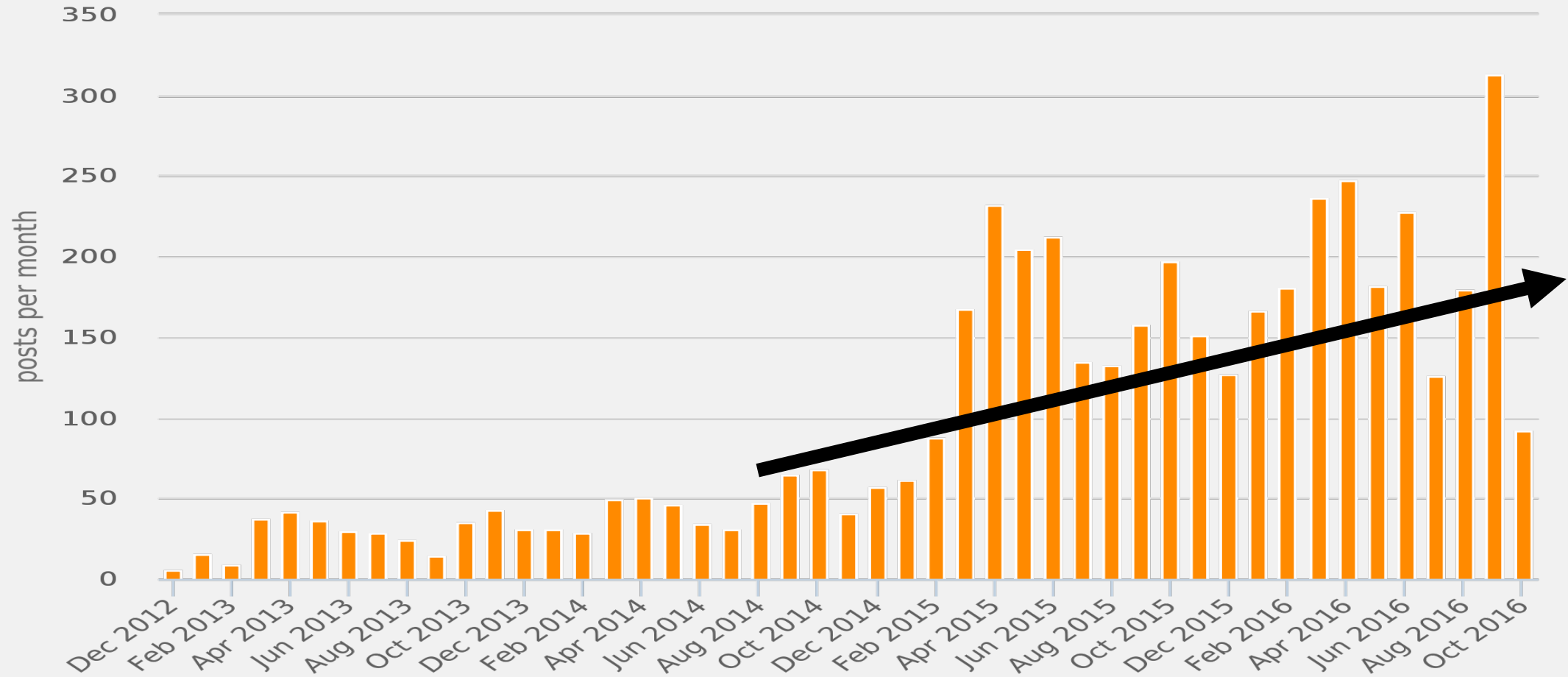



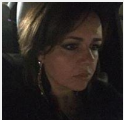
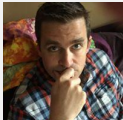

33 Comments

Monthly Post Distribution now over 150

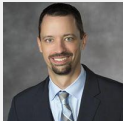

From 2012-12-13 to 2016-10-15

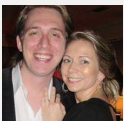
Top Influencers

9554		Conrad Ballecer	4524		Michael Rosen
7641		Shirin Towfigh	4294		Andrew Wright
6000		Brian Jacob	3954		Yuri Novitsky
5040		Yaakov Ulano	3541		JB Bittner
4609		Jorge Daes	3529		Hari Kumar Ondiveeran
4576		Igor Belyansky	2739		Guy Voeller

Quick poll question: Of the two choices below, what has changed or modified your surgical practice or technique more in the past 3 years?

- social media (facebook groups, twitter posts, youtube, etc)
- literature publication (level 1 evidence, guidelines, case reports, etc)

N = 167 surgeons







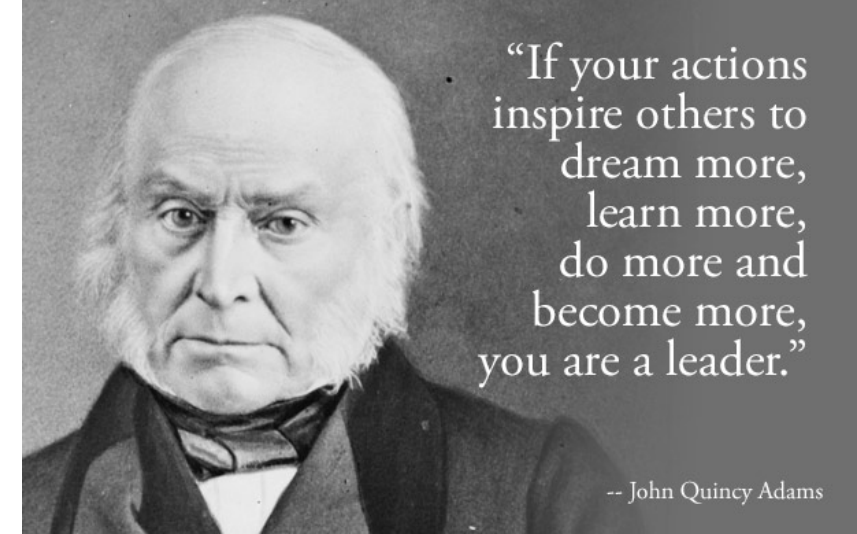

71% of this cohort feel **social media** changed practice
more than literature

Growth of a concept

- Many more successful FB groups
 - Robotics
 - Bariatrics
 - OMF
 - Colorectal
 - SAGES
 - HPB
 - Trauma
 - Cancer
 - HTC
 - Many more



Groups You Manage

 <p>International Hernia Col... (1 unread post, 5+ pending actions)</p>	 <p>SAGES Foregut Surger... (2 unread posts, 5+ pending actions)</p>
 <p>Global Hepato-Pancreat... (3 unread posts, 0 pending actions)</p>	 <p>SAGES Masters Progra... (1 unread post, 0 pending actions)</p>
 <p>SAGES Masters Progra... (1 unread post, 0 pending actions)</p>	 <p>SAGES Masters Progra... (1 unread post, 0 pending actions)</p>
 <p>SAGES Masters Progra... (0 pending actions)</p>	 <p>SAGES Masters Progra... (1 unread post, 0 pending actions)</p>

Interact with experts

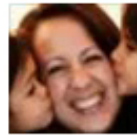

Conrad Ballecer

3 hrs

Robotar: tips and tricks. Long video but can skip to different sections and the different stages of the operation. Sections include adhesiolysis, TAR from top to bottom and bottom to top, retroxiphoid dissection, and the suture trick for mesh placement. 50ish y/o male with a large recurrent incisional and ostomy site hernia.



Robotar Tips and Tricks

Tips and tricks to execute a successful TAR procedure whether its performed in an MIS or open fashion.

YOUTUBE.COM

 Like

 Comment

 Share

The Value of User-Generated Content



Today



- **Risks and Ethics**
 - Discoverability
 - HIPAA
 - Who to believe?
- **Benefits today**
 - Dissemination
 - Crowdreviewed by **peers**
 - Enhanced education
 - Immediate credibility
 - Or discredibility
 - **Voice of the individual**
 - **CQI and mentorship**

Learn How to Post and Collaborate Professionally

**Guidelines For Professionals Using The
International Hernia Collaboration (IHC)
Facebook™ Group
(and social media in general)**

How to maintain value in a Facebook™ Group

- HIPAA compliance officer in the group
- Self –police “noise”
- Easy to discredit those seeking posts purely for ego
- Create technology to provide data to improve value for other stake holders:
 - Patients
 - Hospitals
 - Payors

What is next?

Is it a post or a publication?

July 11, 2016



U.S. Publishing Industry's Annual Survey Reveals Nearly \$28 Billion in Revenue in 2015

**Trends included a return to print and significant
growth of consumer audiobooks as eBooks declined**

STM: International Association of Scientific, Technical and Medical Publishers

- annual revenues generated from English-language STM journal publishing were **10 billion dollars** in 2013
 - 5 billion for ebooks and **5 billion** for journal articles
- industry employs an estimated **110,000** people globally
- **~ 7500** journal **publishers** globally
- **28,100** active scholarly peer-reviewed English-language **journals** in late 2014
 - (\$178,000 per journal yearly)
 - (plus a further 6450 non-English-language journals)
- collectively publishing about **2.5 million articles** a year
 - (estimated value of 2000 dollars per journal article published)

28,100 active scholarly peer-reviewed English-language **journals** in late 2014
(\$178,000 per journal yearly)

- Surgical Endoscopy 2,100,000 yearly
 - Hernia 60,000 yearly

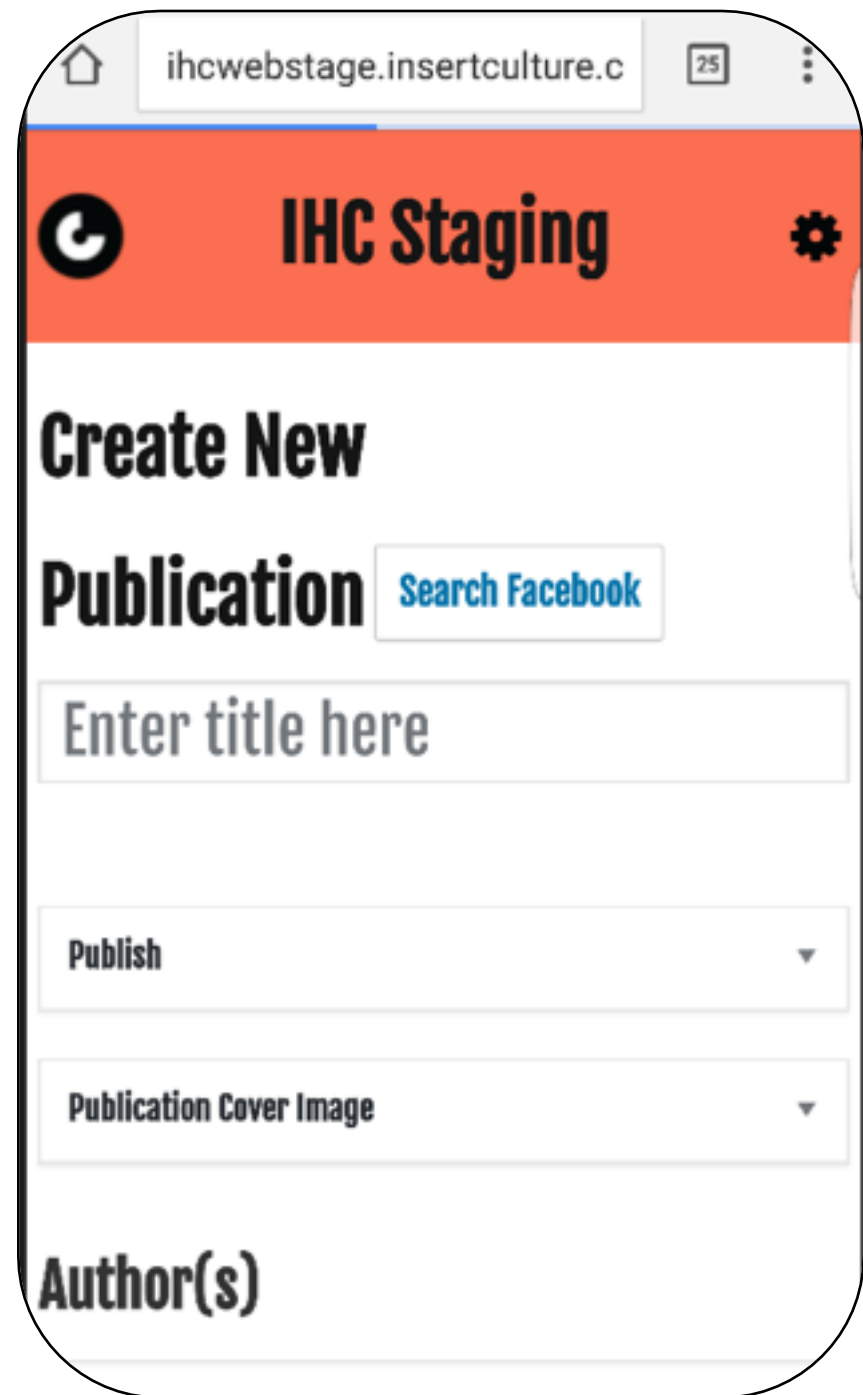
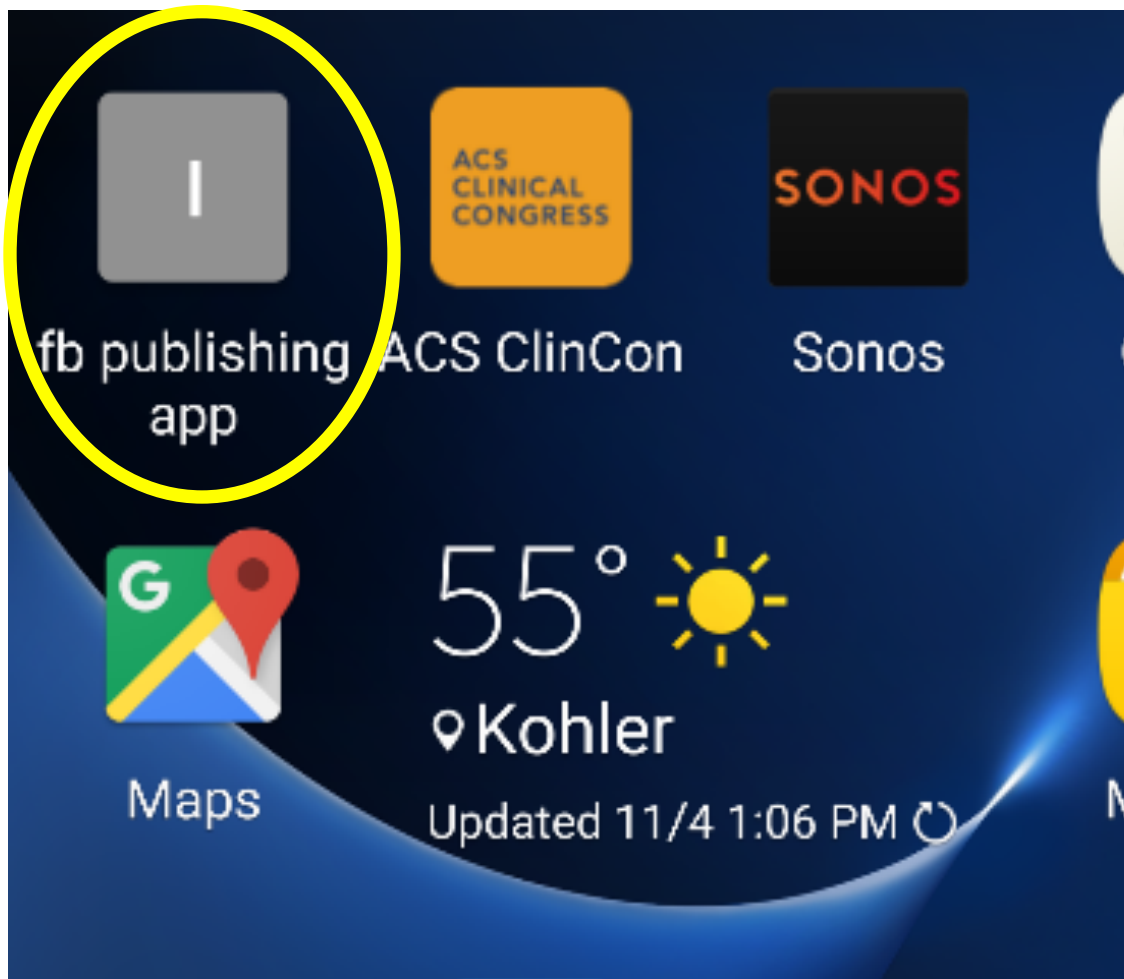

Brian Jacob MD

IHC, inc property. Not for dissemination

Summary

- FB groups are not replacing what we use today
 - Literature
 - Guidelines
 - Registries
- **Social Media will enhance what we use today**
 - Disseminate
 - Educate
 - Mentorship
 - Share
 - Publish